



Tigo[®]

Installation Manual

TS4-A with TAP and CCA



IMPORTANT SAFETY INSTRUCTIONS

LETHAL VOLTAGE MAY BE PRESENT IN ANY PV INSTALLATION

SAVE THESE INSTRUCTIONS

- This manual contains important instructions for installation and maintenance of the Tigo product models TS4-A-O, TS4-A-S, TS4-A-M, Tigo Access Point (TAP), Cloud Connect Advanced (CCA), and related Tigo software and mobile applications.
- Risk of electric shock, do not remove cover, disassemble, or repair, no user serviceable parts inside. Refer servicing to qualified service personnel.
- Before installing or using the Tigo System, please read all instructions and warning markings on the Tigo products, appropriate sections of your inverter manual, photovoltaic (PV) module installation manual, and other available safety guides.
- Failure to adhere to these instructions may result in injury or death, damage to the system, or voiding the factory warranty.
- To reduce risk of fire and shock hazard, install this device with strict adherence to National Electric Code (NEC) ANSI/NFPA 70 and/or local electrical codes. When the photovoltaic array is exposed to light, it supplies a DC voltage to the Tigo TS4 units. The TS4 units start in the "ON" state and their output voltage may be as high as the PV module open circuit voltage (V_{oc}) when connected to the module. The installer should use the same caution when handling electrical cables from a PV module with or without the TS4 units attached.
- Installation must be performed by trained professionals only. Tigo does not assume liability for loss or damage resulting from improper handling, installation, or misuse of products.
- Remove all metallic jewelry prior to installing the Tigo TS4 units to reduce the risk of contacting live circuitry. Do not attempt to install in inclement weather.
- Do not operate the Tigo TS4 units if they have been physically damaged. Check existing cables and connectors, ensuring they are in good condition and appropriate in rating. Do not operate Tigo TS4 units with damaged or substandard wiring or connectors. Tigo TS4 units must be mounted on the high end of the PV module backsheet or racking system, and in any case above ground.
- Do not connect or disconnect under load. Turning off the Inverter and/or the Tigo products may not reduce this risk. Internal capacitors within the inverter can remain charged for several minutes after disconnecting all power sources. Verify capacitors have discharged by measuring voltage across inverter terminals prior to disconnecting wiring if service is required. Wait 30 seconds after rapid shutdown activation before disconnecting DC cables or turning off DC disconnect.
- Always assume TS4 units are in "ON" state, or may turn on when restarting.
- The CCA must be on the same AC branch circuit as the inverter to meet rapid shutdown requirements.

TABLE OF CONTENTS

Tigo System Overview	4	Appendix	25
TS4 Flex MLPE Functions	5	Technical Specifications – TS4-A-M & TS4-A-S	26
Communication Accessories	6	Technical Specifications – TS4-A-O	27
System Overview: TS4-A	7	Technical Specifications – CCA & TAP	28
MLPE Installation Notes	8	Testing Rapid Shutdown	29
String Design With TS4-A	9	TAP Placement - Legacy (Pre-Mesh)	30
TS4-A Installation	10	Miscellaneous	31
Communication Installation	11	Installation Complete	32
TAP Installation - Mesh Configuration	12		
TAP Placement Example - Mesh	13		
CCA Installation	14		
CCA LED Status Guide	15		
CCA & TAP Wiring	16		
Modbus RS-485 Wiring Diagram & Configuration Template	17		
Configuration, Registration, & Commissioning	18		
Tigo SMART App	19		
Getting Started	20		
Select Equipment	21		
Configure Module Layout	22		
Connect CCA To Smartphone	23		
Configure Network Settings – Connect CCA To Internet	24		
Commission The TS4-A Units – Run Discovery	24		

TIGO SYSTEM OVERVIEW

Module Level Power Electronics:



TS4-A

Modular smart electronics platform

Communication Accessories:

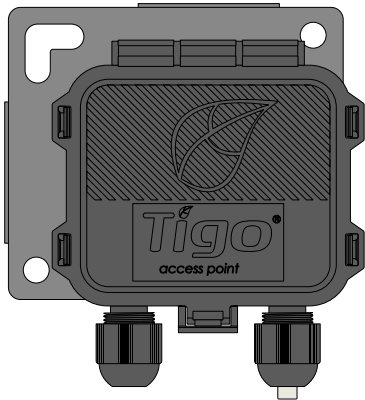

Tigo Access Point (TAP)

Wireless communication device for monitoring and safety features

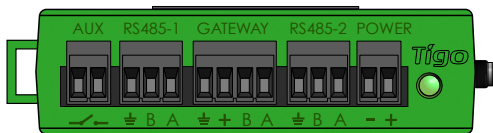

Cloud Connect Advanced (CCA)

Data logger and rapid shutdown control

TS4 FLEX MLPE FUNCTIONS

The TS4 Flex MLPE platform is incremental in functionality. Select the TS4 version with features that best address the needs of your project.

MONITORING

TS4-A-M

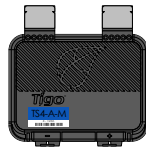

Monitoring

- Reduced O&M costs
- PV-2.0 data synchronization
- Module bar code tracking
- CRM integration
- Warranty tracking
- Fleet management

SAFETY

TS4-A-S

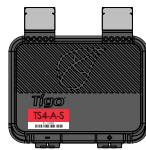

Monitoring



Safety

- NEC 2017 & 2020 690.12 rapid shutdown compliant
- Module-level deactivation
- Automatic or manual shutdown
- Plus all the benefits of Monitoring

OPTIMIZATION

TS4-A-O

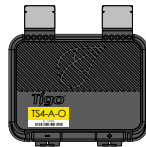

Monitoring



Safety



Optimization

- Shade and mismatch tolerance
- Enhanced energy yield
- Greater design flexibility
- Maximized roof usage
- Plus all the benefits of Safety and Monitoring

For the **TS4-F (Fire Safety)** manual, [click here](#)

COMMUNICATION ACCESSORIES

Tigo Access Point (TAP)

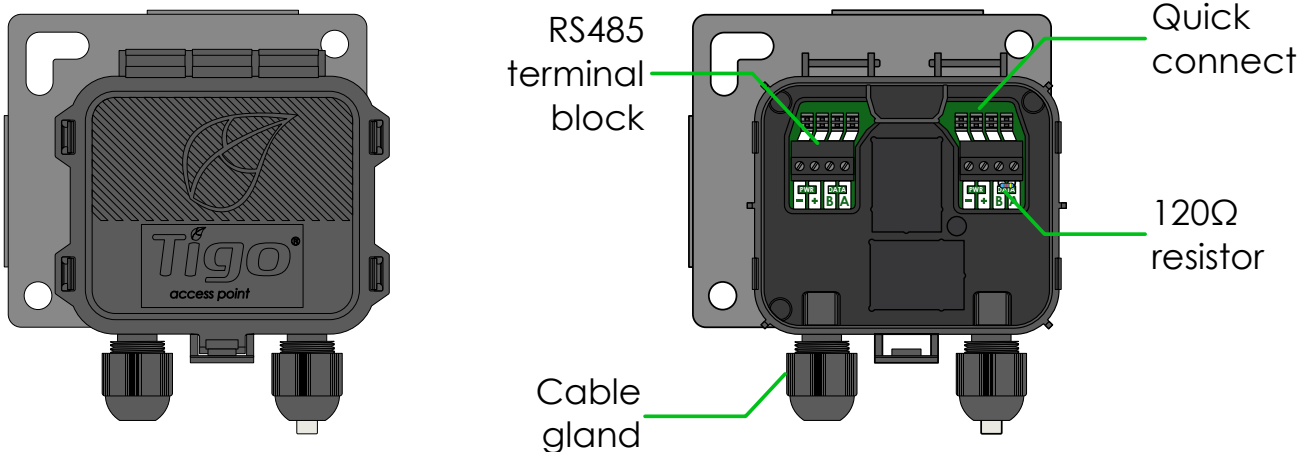

Mesh configuration:

- 300 TS4 units per TAP
- 900 TS4 units per CCA
- 7 TAPs per CCA

Wireless range:

- 33ft (10m) max between TAP and closest TS4 unit
- 115ft (35m) max between TAP and farthest TS4 unit using mesh

Legacy configuration:

- Same as Gateway, see [appendix](#) for more details

Cloud Connect Advanced (CCA)

- CCA is required for monitoring and rapid shutdown
- CCA is optional for optimization and long strings
- Install near inverter with access to AC power and internet
 - Ethernet and Wi-Fi are built-in

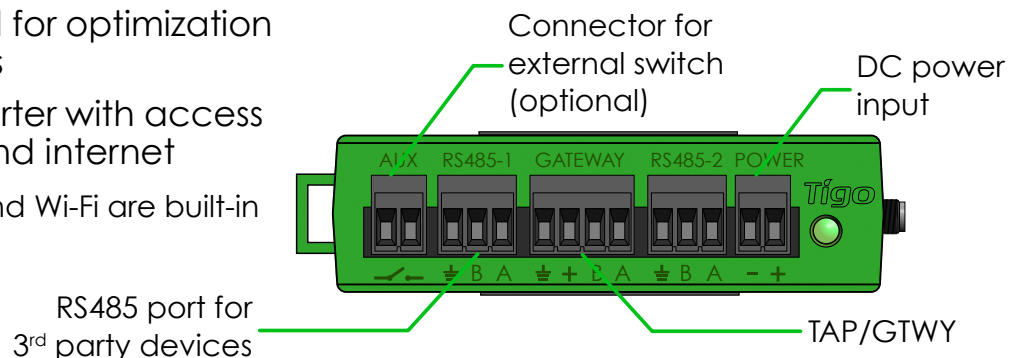

SYSTEM OVERVIEW: TS4-A

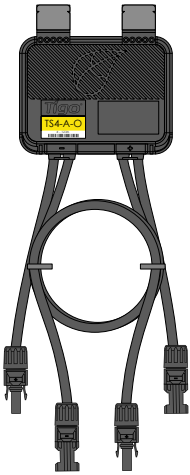

TS4-A

- Bracket clips to module frame without tools
- TS4-A inputs connect to module junction box, TS4-A outputs are connected in series to form a string
- No additional grounding required

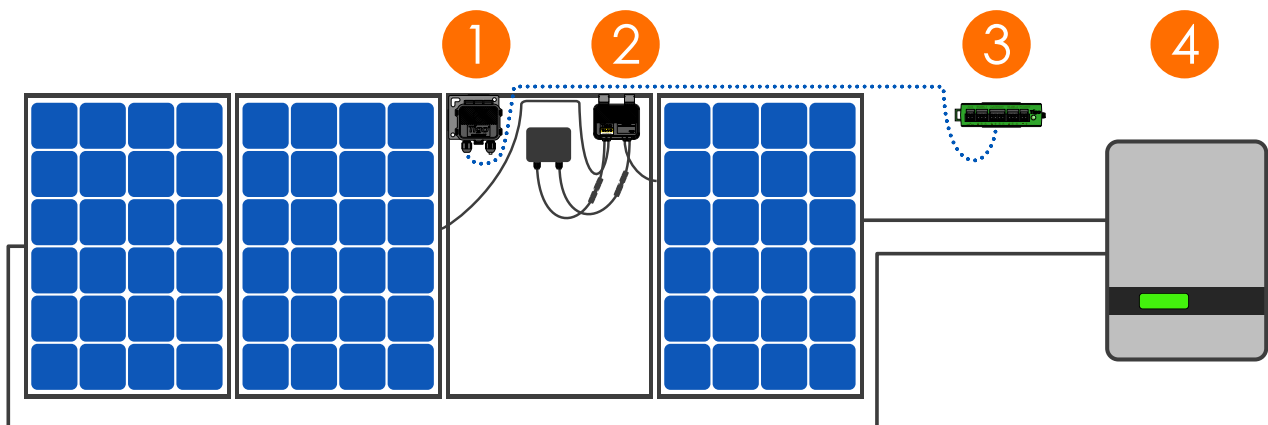

1. Tigo Access Point (TAP)
2. TS4-A installed on standard module
3. Cloud Connect Advanced (CCA)
4. Inverter

Note: connect modules to TS4-A inputs before connecting outputs

- TS4-A mounting is recommended on the upper right as shown, but can be placed on upper left if needed (due to racking constraints, etc.)
- TS4-A cable glands must not be facing up
- Allow clearance between PV module and mounting surface for air circulation around TS4-A
- Do not drill additional mounting holes in the frame or metal bracket

MLPE INSTALLATION NOTES

- Note: The following TS4 products are shipped in the ON position:
 - TS4-M, TS4-S, TS4-O
 - TS4-A-M, TS4-A-S, TS4-A-O
- Upon exposure of the PV module to sunlight high voltage is present. Handle with the appropriate precautionary measures.
- Optimization feature does not require CCA & TAP for operation.
- To enable Monitoring and Safety features:
 - Collect the TS4 removable barcode label, install and commission with CCA & TAP.

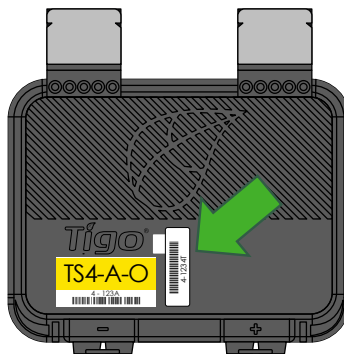

Module frame specifications for mounting TS4-A:

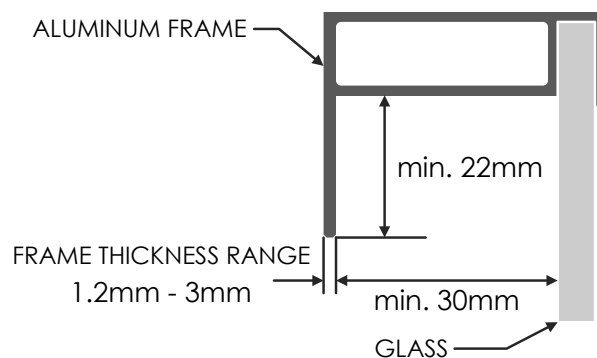

With add-on units, failing to follow the sequence of installation steps may result in TS4 damage not covered under warranty.

STRING DESIGN WITH TS4-A

TS4-A-M: MONITORING:

Standard rules for string length and design.
Requires CCA and TAP for monitoring.



TS4-A-S: SAFETY:

Standard rules for string length and design.
Requires CCA and TAP for monitoring and rapid shutdown.



TS4-A-O: OPTIMIZATION:

Standard rules for string length
Flexible design (mixed orientations, unequal length strings in parallel)
Tolerant of shade and mismatch

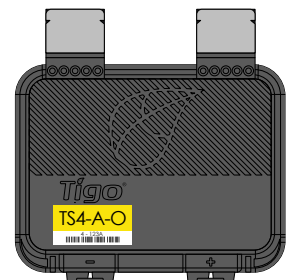

TS4-A INSTALLATION

Standard modules can be equipped with TS4-A add-on units as shown below.

Always connect modules to TS4-A inputs before connecting outputs.

Each TS4-A must have a PV module connected to its inputs before connecting the outputs of TS4-A units in series.

To disconnect TS4-A from a module, disconnect the TS4-A outputs from the string before disconnecting the TS4-A inputs from the module junction box.

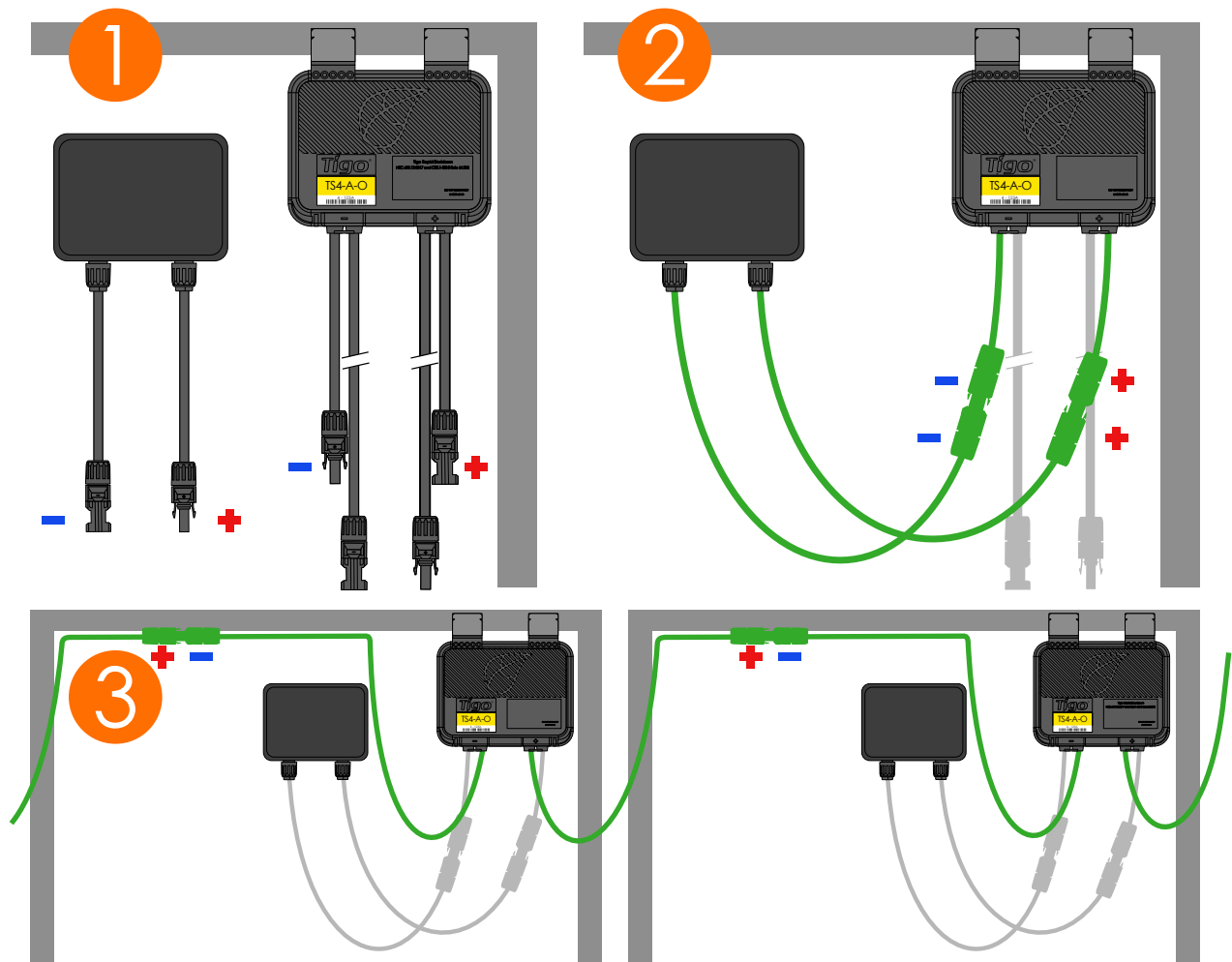

COMMUNICATION INSTALLATION

COMMUNICATION DESIGN RULES

- MESH CONFIGURATION
 - 300 TS4 units per TAP
 - 900 TS4 units per CCA
 - 7 TAPs per CCA
 - 33ft (10m) max between TAP and closest TS4 unit
 - 115ft (35m) max wireless range using mesh
 - No more than 10m between TS4 units on same TAP
- LEGACY CONFIGURATION
 - 120 TS4 units per TAP
 - 360 TS4 units per CCA
 - 7 TAPs per CCA
 - 50ft (15m) radius with line of sight between TAP & all TS4 units

Wireless signal range can be affected by solid obstructions. Refer to [TAP Placement Guide](#) for more information.

NOTES

- All TS4 units in the same string must be assigned to the same CCA.
- For further design information, [click here](#).

CCA and TAP CALCULATOR

- To estimate the number of CCAs and TAPs required for your project, [click here](#).

TAP INSTALLATION - MESH CONFIGURATION

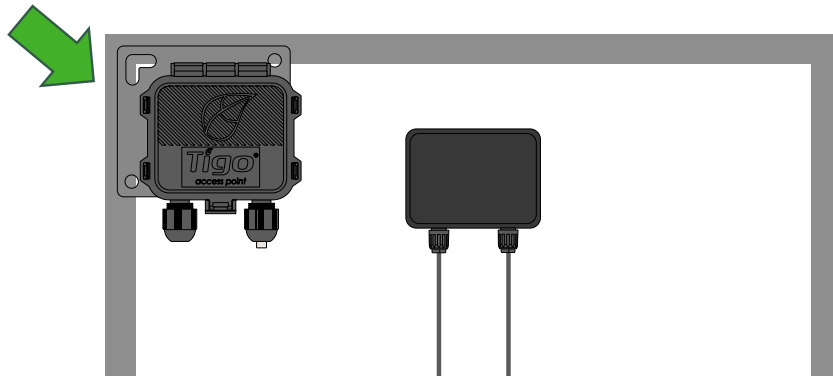

TAP attaches to module frame using built-in bracket. Mounting holes are also available in case of frameless modules.

Place TAP within 10m of any TS4 unit in the array, with a maximum distance of 10m between TS4 units and 35m from TAP to farthest TS4.

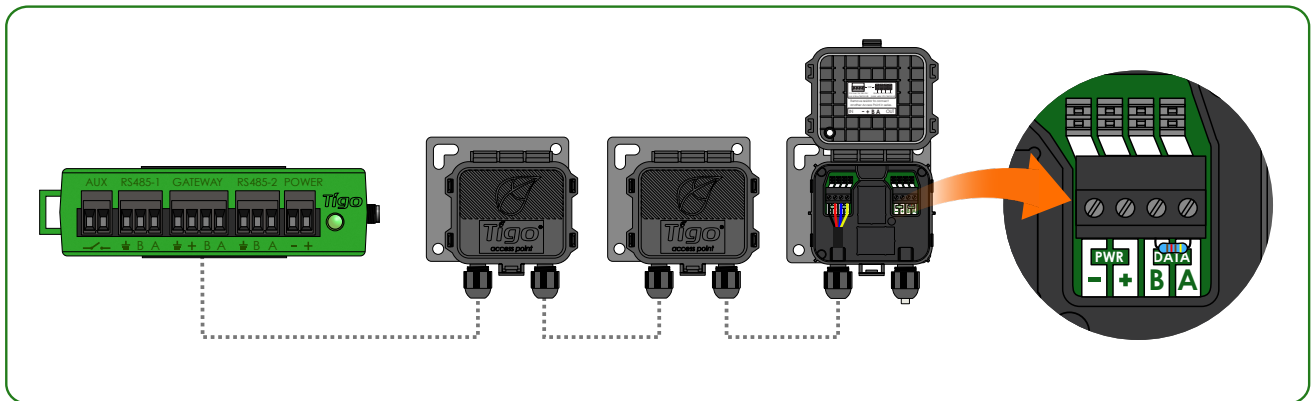

Connect multiple TAP units in series and leave terminating resistor in final TAP only.

Use 4-conductor RS485 (18-22 AWG) cable between TAP and CCA.

[Click here](#) for more information on TAP placement.

TAP PLACEMENT EXAMPLE - MESH

230ft (70m) max

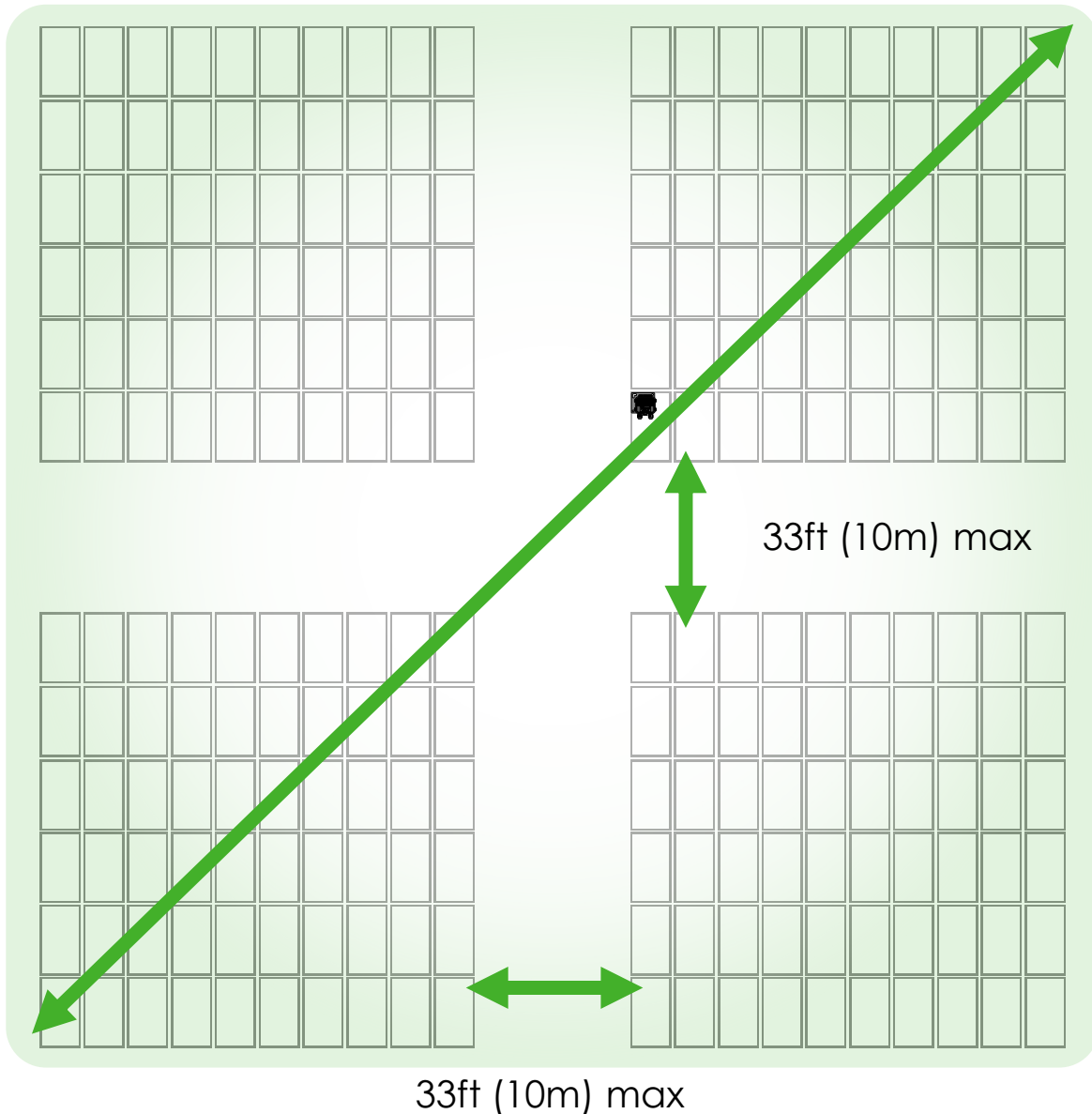

Place TAP within 10m of any TS4 unit in the array.

Maximum distance of 10m between TS4 units that belong to a single TAP.

Maximum distance of 35m (115ft) between TAP and farthest TS4 unit.

Connect multiple TAPs in series for larger arrays.

CCA INSTALLATION

- CCA is required for monitoring and rapid shutdown
- Optional for optimization and long strings
- Install near inverter with access to AC power and internet
 - Ethernet and Wi-Fi are built-in

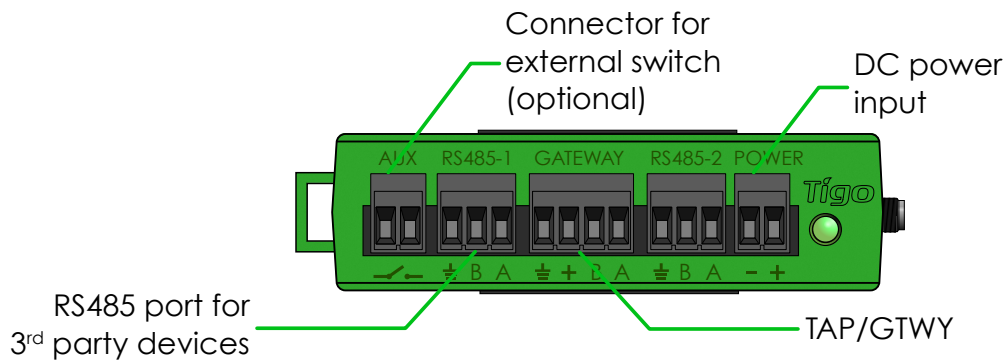

CCA and TAP are required for Rapid Shutdown control

Install CCA on same AC main service as inverter for automatic activation in case of AC grid loss

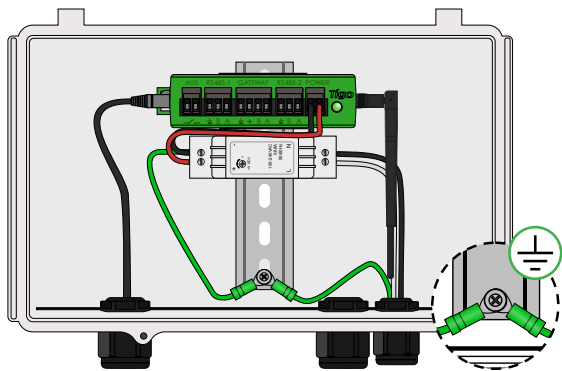

CCA with DIN rail power supply

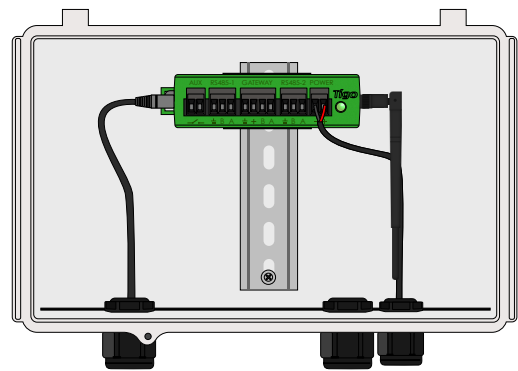

CCA with DC transformer

- Connect DC leads from power supply to CCA
- Connect AC and DC ground wires to DIN rail
- Connect AC power input to power supply
- Connect DC leads from power supply to CCA

Complete TAP wiring connections before powering on CCA

CCA LED STATUS GUIDE

Auto PV-Off



- A blinking red and yellow LED indicates that the system automatically entered PV-Off mode.

Error



- A solid red LED indicates that the Discovery process failed or that the CCA is not able to connect to the Tigo server. In case of errors, connect to the CCA using the mobile app for more details.

User PV-Off



- A blinking green and yellow LED indicates that PV-Off mode was activated manually.

Warning



- A solid yellow LED indicates that: Discovery has not been run, Discovery completed but did not find all expected TAPs or TS4 units, or CCA is not able to upload data. Connect to the CCA using the Tigo SMART app for more details.

SMART App Activity



- A blinking green LED indicates that the mobile app is connected to the CCA and is actively in use.

System OK



- A solid green LED indicates that Discovery is complete and found all expected TAPs and TS4 units, and CCA is able to connect to the Tigo server.

Discovery



- A blinking yellow LED indicates that the CCA is scanning for TAPs and TS4 units (part of the commissioning process).

Power Off / No Status



- An unlit LED indicates that the CCA is powered off.

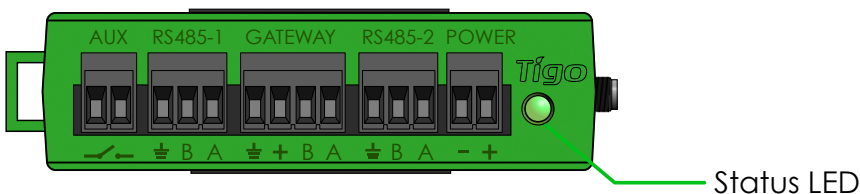

Status LED

CCA & TAP WIRING

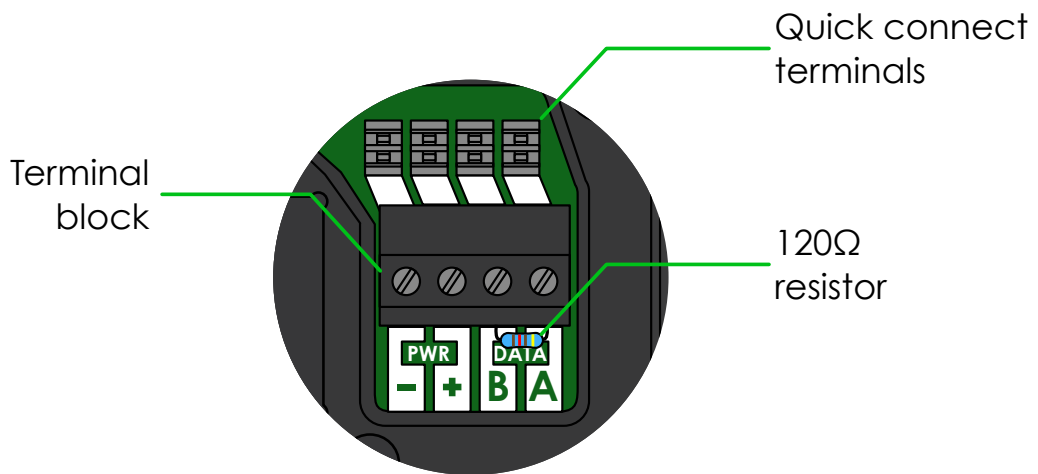
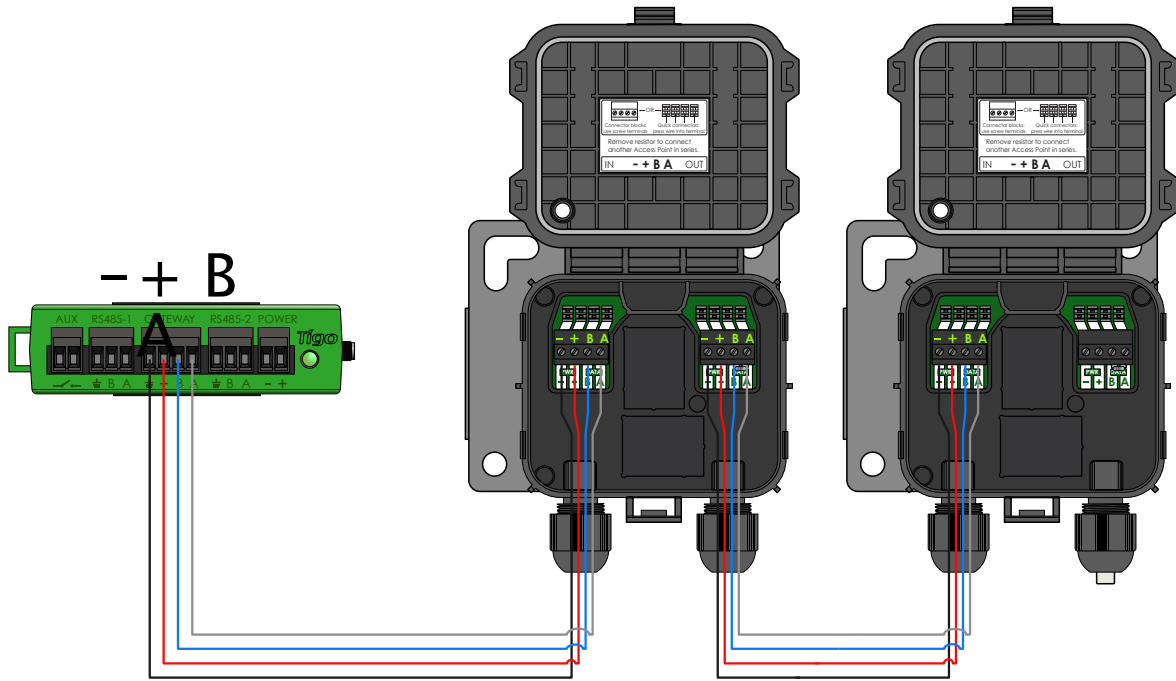

Connect multiple TAP units in series and leave terminating resistor only in final TAP.

If using the quick connectors, remove the terminal block from the TAP and strip approximately 3cm of insulation from the end of the cable.

Use a small flathead screwdriver to press the conductors into the quick connectors. The individual conductors do not require stripped ends.

Connect all communication cables before powering on CCA.

MODBUS RS-485 WIRING DIAGRAM & CONFIGURATION TEMPLATE

- Up to 32 Modbus RS-485 devices can be connected to a single Cloud Connect/CCA
- All devices must have a unique Modbus address
- All devices connected in series must have the same baud rate, parity, and stop bit settings
- Check device manual for Modbus settings

Cloud Connect Advanced (CCA)

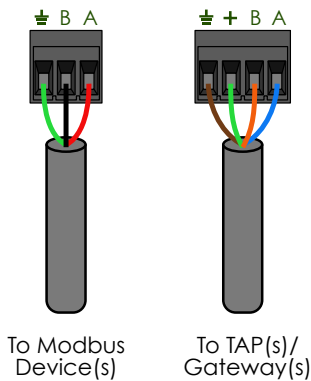
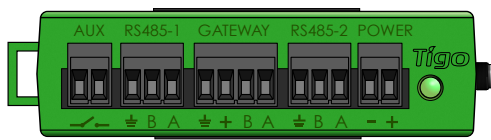

RS-485 communication cable with shield

<p>Modbus Device #1</p> <p>Manufacturer: _____</p> <p>Model: _____</p> <p>Type of Device: _____</p> <p>Electrical Voltage: _____</p> <p>Single or 3 Phase: _____</p> <p>CT Rating: _____</p> <p>Modbus Address: _____</p> <p>Baud Rate: _____</p> <p>Parity: _____</p> <p>Stop Bits: _____</p> <p>RS-485 Modbus terminal</p>	<p>Modbus Device #2</p> <p>Manufacturer: _____</p> <p>Model: _____</p> <p>Type of Device: _____</p> <p>Electrical Voltage: _____</p> <p>Single or 3 Phase: _____</p> <p>CT Rating: _____</p> <p>Modbus Address: _____</p> <p>Baud Rate: _____</p> <p>Parity: _____</p> <p>Stop Bits: _____</p> <p>RS-485 Modbus terminal</p>
--	--

<p>Modbus Device #1</p> <p>Manufacturer: _____</p> <p>Model: _____</p> <p>Type of Device: _____</p> <p>Electrical Voltage: _____</p> <p>Single or 3 Phase: _____</p> <p>CT Rating: _____</p> <p>Modbus Address: _____</p> <p>Baud Rate: _____</p> <p>Parity: _____</p> <p>Stop Bits: _____</p> <p>RS-485 Modbus terminal</p>	<p>Modbus Device #2</p> <p>Manufacturer: _____</p> <p>Model: _____</p> <p>Type of Device: _____</p> <p>Electrical Voltage: _____</p> <p>Single or 3 Phase: _____</p> <p>CT Rating: _____</p> <p>Modbus Address: _____</p> <p>Baud Rate: _____</p> <p>Parity: _____</p> <p>Stop Bits: _____</p> <p>RS-485 Modbus terminal</p>
--	--

120Ω resistor across + and - terminals on the last Modbus device in series

[Click here](#) for more info about setting up inverters, meters, & sensors

CONFIGURATION, REGISTRATION, & COMMISSIONING

- For residential systems, perform configuration, registration, and commissioning via the Tigo SMART App.
- For non-residential systems, perform site configuration online at <https://smart.tigoenergy.com>.

Recommended procedure:

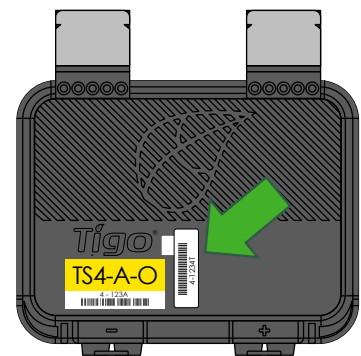

OR

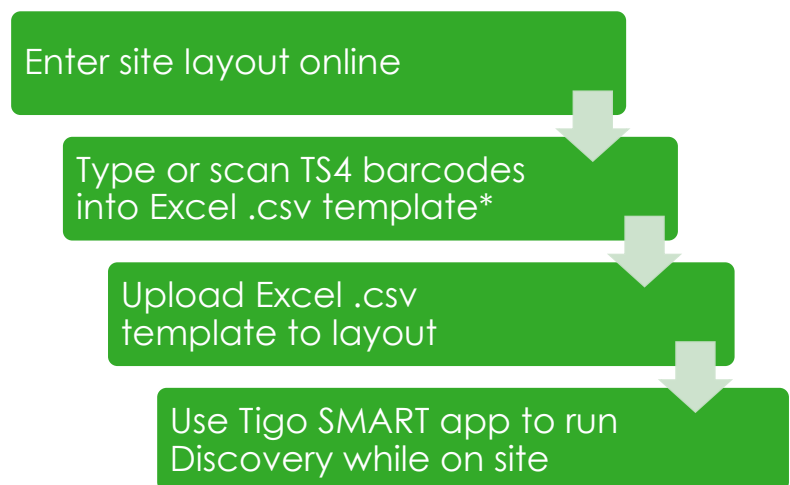

* Download the pre-formatted .csv template from the Layout step of the site builder

TIGO SMART APP

Commissioning a new system using the Tigo App 3.0

Use the Tigo SMART app to:

- Create a system
- Input owner info
- Enter inverter & module types
- Configure layout and scan barcodes
- Configure network
- Commission Tigo hardware
- Monitor production



Install 'Tigo SMART' from the App Store or Google Play

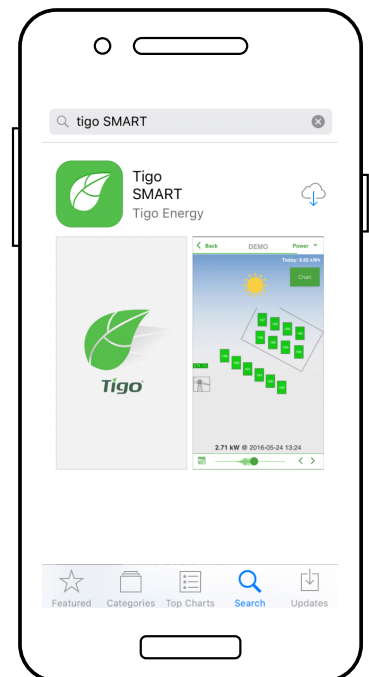

GETTING STARTED

Requires active mobile data connection

If you do not have an installer account, tap 'Enroll' to create a new account. All system data can also be accessed and edited here: smart.tigoenergy.com

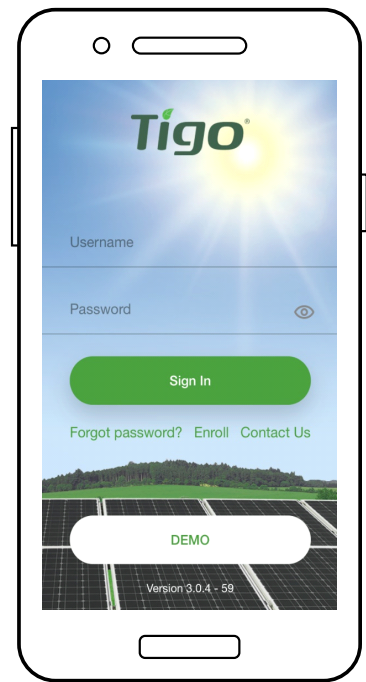

To proceed with a new installation, tap '+' at the top right of the display

To service or monitor an existing system that has already been configured, tap on that system in your list

Enter a name and address for the new system and create a user account for the system owner

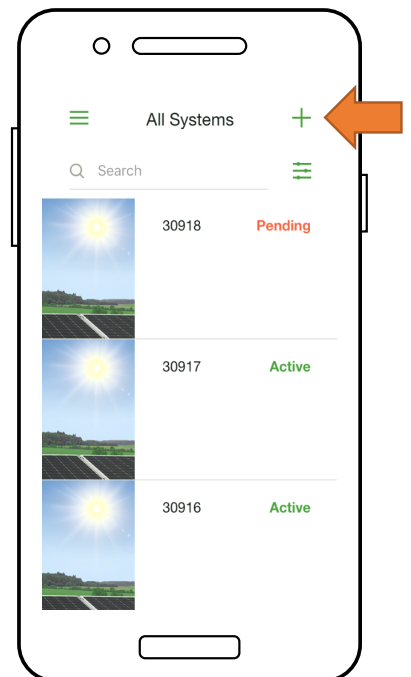

SELECT EQUIPMENT

Requires active mobile data connection

- Go to **'Select Equipment'**
- Tap **'+'** at the top right of the display to add equipment
- Choose the inverter model, the number of MPPTs, and the associated CCA
- Select the manufacturer and model of the PV modules
- **Note:** If using an inverter or module not in the list, click the **'+'** sign at the top right corner

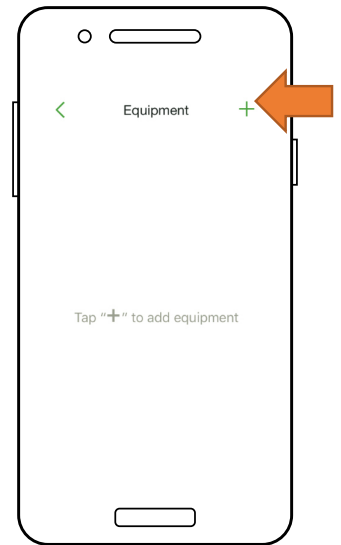
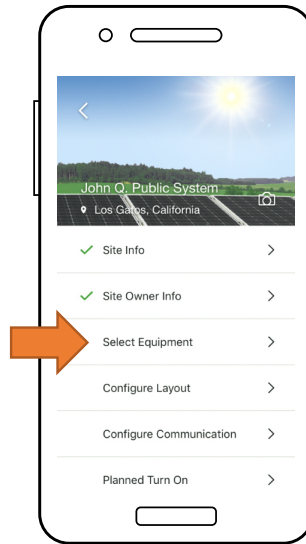

- Place the CCA by tapping on a position on the Layout grid
- Tap **'Place'** next to an equipment type to place it on the grid
- Repeat for all CCAs and inverters

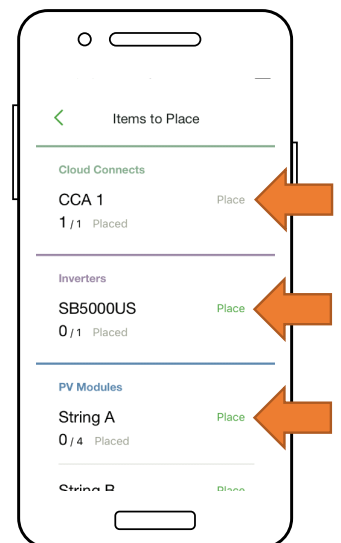
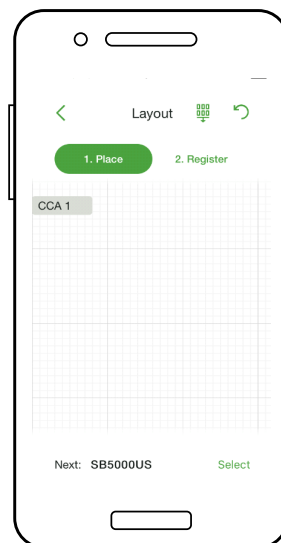

CONFIGURE MODULE LAYOUT

Requires active mobile data connection

- Place modules in the Layout grid according to their physical placement on site
- **Note:** Matching the physical map of the system is optional but improves its appearance in the monitoring portal and makes maintenance easier
- Tap and drag to change the position of a placed item
- Tap 'Register' to begin entering the TS4 barcodes

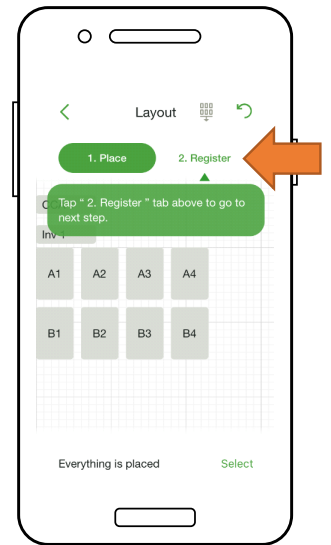
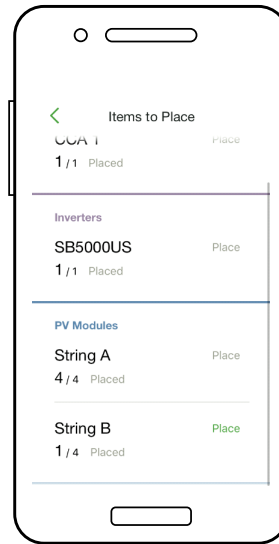

- Place the CCA by tapping on a position on the Layout grid
- Tap 'Place' next to an equipment type to place it on the grid
- Repeat for all CCAs and inverters

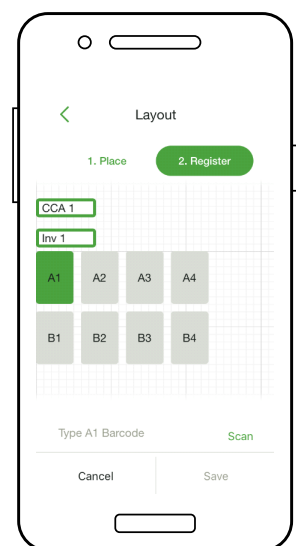
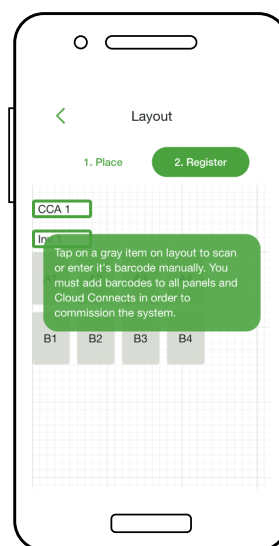

CONNECT CCA TO SMARTPHONE

No mobile data connection required

- To connect the Smartphone to the CCA via **Bluetooth**, tap the serial number of the CCA you wish to connect with
- **Note:** Use the Tigo Smart App to pair with the CCA, instead of the phone's Bluetooth pairing screen
- Once connected to the CCA, tap '**Next**' to continue

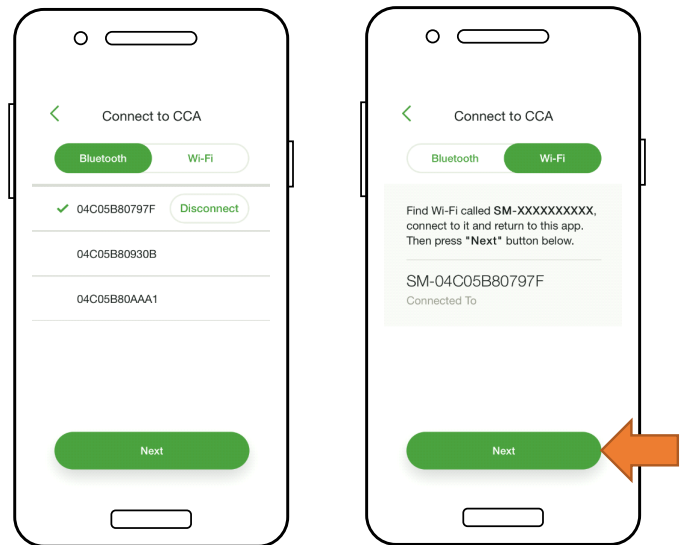

- To connect the smartphone to the CCA via **Wi-Fi**, choose the CCA's Wi-Fi connection in the phone's settings
- **Note:** Using the Wi-Fi connection disconnects the smartphone from the local Wi-Fi
- Once connected to the CCA, tap '**Next**' to continue

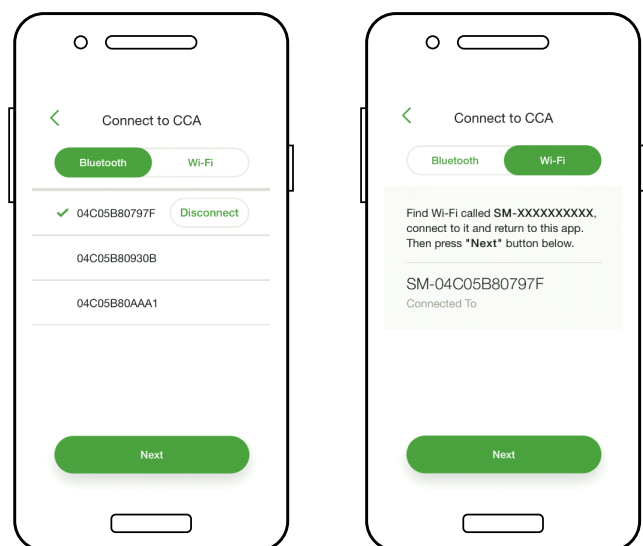

CONFIGURE NETWORK SETTINGS – CONNECT CCA TO INTERNET

Requires smartphone – CCA connection

- The Network Test checks the Internet connection of the CCA
- The test performs a series of checks that can be used for troubleshooting the network connection
- Tap '**Done**' to continue

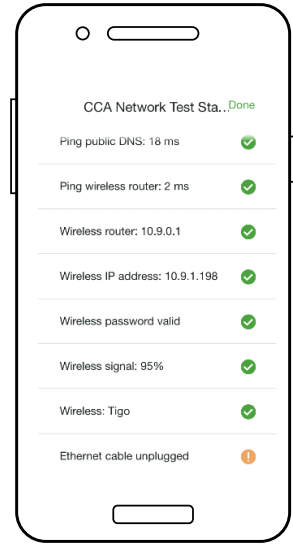
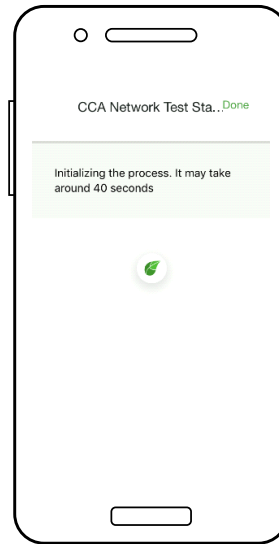

COMMISSION THE TS4-A UNITS – RUN DISCOVERY

Requires smartphone – CCA connection

- Tap '**Next**' in the 'CCA Network Settings' to go to 'Discovery'
- **Note:** Before starting Discovery, all site equipment and TS4 barcodes should be input into the app. Begin the process no later than an hour before sunset.
- Tap '**Start**' to run Discovery
 - When Discovery is complete, system production data can be viewed online and in the app

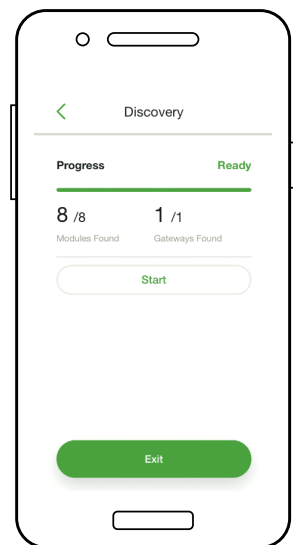
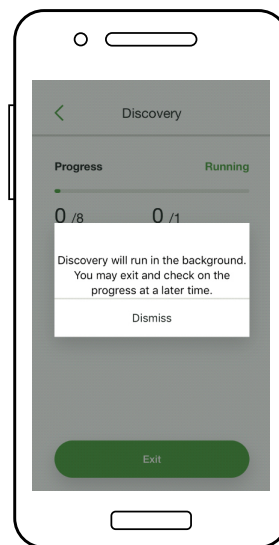



Tigo[®]

Appendix

Product Specifications, Rapid Shutdown,
Legacy Communication

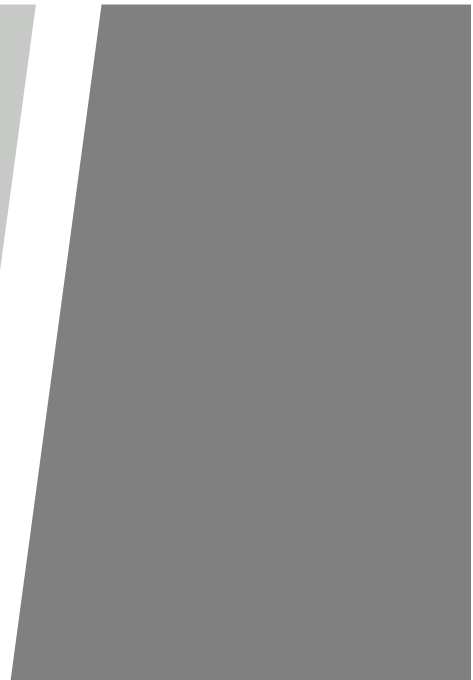

TECHNICAL SPECIFICATIONS – TS4-A-M & TS4-A-S



MONITORING
TS4-A-M



SAFETY
TS4-A-S

Electrical Ratings

Input		
Rated DC Input Power	700W	700W
Input Voltage	16 - 90V	16 - 90V
Max Continuous Input Current (I _{MAX})	15A	15A
Output		
Output Power Range	0 - 700W	0 - 700W
Output Voltage Range	0 – V _{OC}	0 – V _{OC}
Communication Type	Wireless	Wireless
Rapid Shutdown UL Listed ¹ (NEC 2017 & 2020 690.12)	Need additional RS device	Yes
Impedance Matching	No	No
Output Voltage Limit	No	No
Maximum System Voltage	1500V	1500V

¹ Cloud Connect Advanced (CCA) and TAP/Gateway required for rapid shutdown compliance with TS4-A-S & TS4-A-O.

Mechanical

Operating Temperature Range (IEC)	-40°C to +85°C (-40°F to +185°F), RH < 85%
Operating Temperature Range (UL)	-30°C to +75°C (-22°F to +167°F), RH < 85%
Storage Temperature Range	-40°C to +85°C (-40°F to +185°F), RH < 60%
Cooling Method)	Natural Convection
Dimensions	138.4mm x 139.7mm x 22.9mm
Weight	490g
Outdoor Rating	IP68

Cabling

Type	H1Z2Z2-K
Input Cable Length	0.12 (standard), 0.62 (optional)
Output Cable Length	1.2m
Rating Options ³	1000V, 1500V
Cable Cross-Section	6.3 ± 0.3mm
Connectors	MC4 (standard), MC4 comparable, EVO2
UV Resistance	500hr with UV light between 300-400nm @65°C

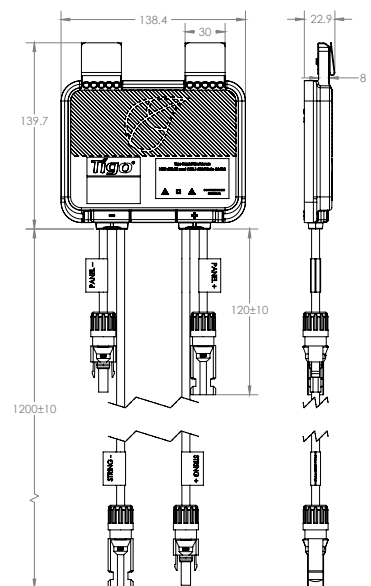

TECHNICAL SPECIFICATIONS – TS4-A-O



OPTIMIZATION TS4-A-O

Electrical Ratings

Input	
Rated DC Input Power	700W
Input Voltage	16 - 80V
Max Continuous Input Current (I _{MAX})	15A
Output	
Output Power Range	0 - 700W
Output Voltage Range	0 – V _{oc}
Communication Type	Wireless
Rapid Shutdown UL Listed ¹ (NEC 2017 & 2020 690.12)	Yes
Impedance Matching	Yes
Output Voltage Limit	No
Maximum System Voltage	1000V / 1500V



¹ Cloud Connect Advanced (CCA) and TAP/Gateway required for rapid shutdown compliance with TS4-A-S & TS4-A-O.

Mechanical

Operating Temperature Range	-40°C to +70°C (-40°F to +158°F), RH < 85%
Storage Temperature Range	-40°C to +70°C (-40°F to +158°F), RH < 60%
Cooling Method)	Natural Convection
Dimensions	W= 138.4mm, L= 139.7mm, H= 22.9mm
Weight	490g
Outdoor Rating	IP68

Cabling

Type	H1Z2Z2-K
Input Cable Length	0.12 (standard), 0.62 (optional)
Output Cable Length	1.2m
Rating Options ³	1000V, 1500V
Cable Cross-Section	6.3 ± 0.3mm
Connectors	MC4 (standard), MC4 comparable, EVO2
UV Resistance	500hr with UV light between 300-400nm @65°C

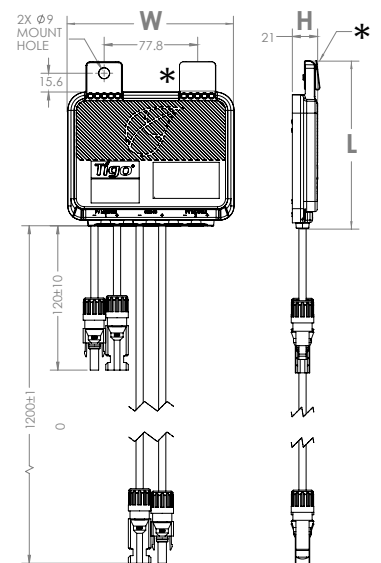

*Clips can be removed for rack mounting

TECHNICAL SPECIFICATIONS – CCA & TAP

Electrical	
CCA	
Input Voltage	10V _{DC} - 25V _{DC}
Power Consumption	3W - 7W
Power Supply	
	138.4mm x 139.7mm x 22.9mm
Input Voltage	100V _{AC} - 240V _{AC}
Mechanical	
DIN rail mountable enclosure	
Dimensions (CCA only)	31mm x 115.51mm x 71.54mm
Weight (CCA only)	126g
Operating Temperature Range	-20°C to +70°C (-4°F to +158°F)
Cooling	Natural Convection
Capacity	
Mesh Configuration	Each CCA supports up to 900 TS4 units and up to 7 TAPs
Legacy Configuration	Each CCA supports up to 360 TS4 units and up to 7 TAPs
User Interface	

[Mobile App: Tigo SMART App for Android and iOS](#)

[Multi-function LED status indicator](#)

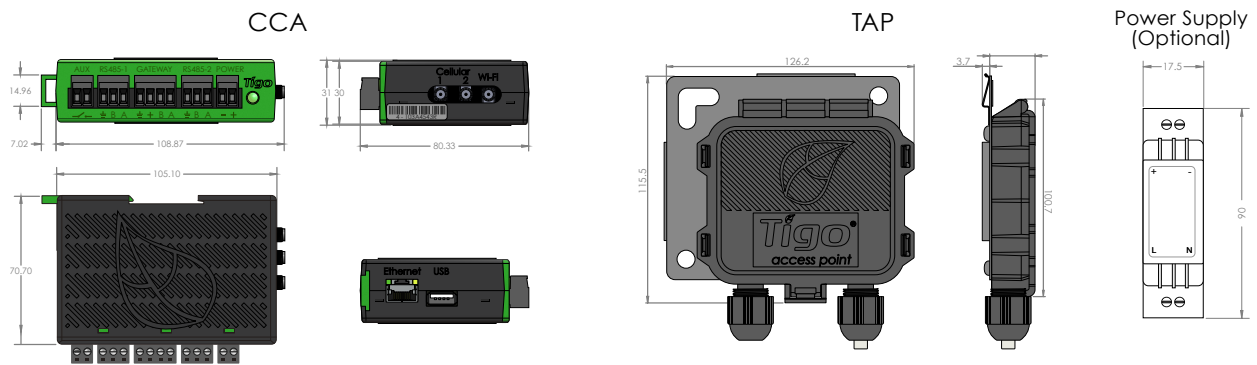

All dimensions in mm.

Electrical	
TAP	
Input Voltage	24V _{DC}
Mechanical	
Dimensions	126.2mm x 130.0mm x 26.8mm (with bracket)
Weight	227g
Operating Temperature Range	-20°C to +85°C (-4°F to 185°F)
Environmental Rating	IP68, Type 4R
Cooling	Natural Convection
Capacity	
Mesh Configuration	300 TS4 units up to 115ft (35m) away
Legacy Configuration	120 TS4 units up to 50ft (15m) away

TESTING RAPID SHUTDOWN

TS4-O, TS4-S, TS4-A-S, and TS4-A-O installed with Cloud Connect Advanced and TAP are a solution to meet the NEC 2017 & 2020 690.12 Rapid Shutdown requirements.

TS4 units with the safety feature automatically enter rapid shutdown mode when the CCA is switched off and resume energy production when power is restored to the CCA.

Wait 30 seconds after rapid shutdown activation before disconnecting DC cables or turning off DC disconnect.

Test your rapid shutdown system by switching off the AC power to the CCA.

TS4 units with the safety feature will reduce their output to 0V when the CCA is powered off.

SOLAR PV SYSTEM EQUIPPED WITH RAPID SHUTDOWN



TURN RAPID SHUTDOWN SWITCH TO THE "OFF" POSITION TO SHUT DOWN PV SYSTEM AND REDUCE SHOCK HAZARD IN ARRAY

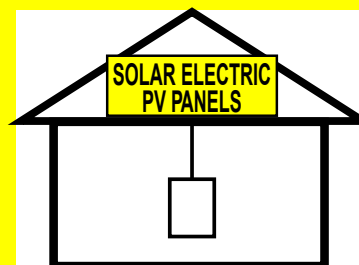

WHEN USED WITH **Tigo TS4**

Place safety labels in proper location

The CCA power supply MUST be on the same AC branch circuit as the inverter to meet rapid shutdown requirements.

[Click here](#) for more info about Rapid Shutdown

TAP PLACEMENT - LEGACY (PRE-MESH)

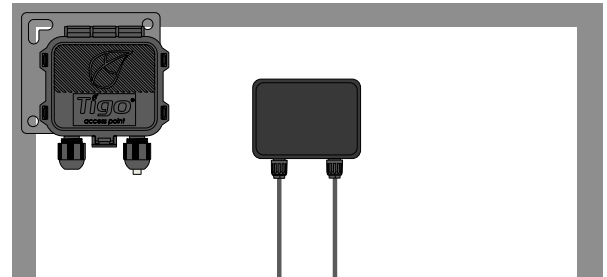
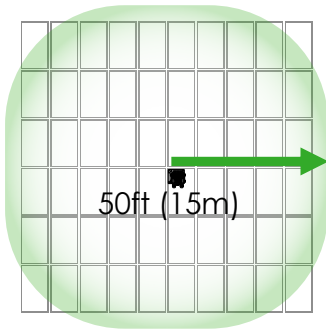

Place TAP near center of array or each sub-array.

TAP attaches to module frame using built-in bracket. Mounting holes are also available in case of frameless modules.

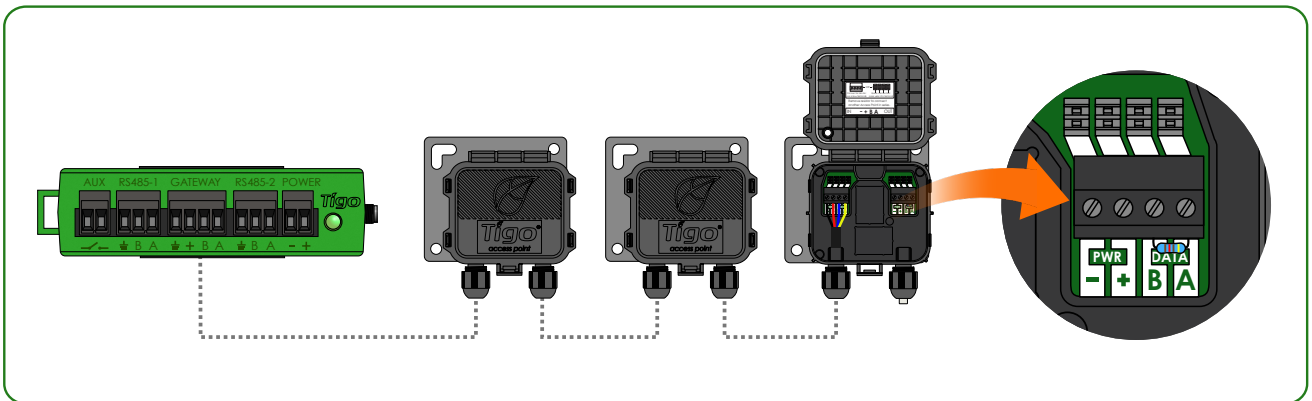

Connect multiple TAP units in series and leave terminating resistor in final TAP only.

Use 4-conductor RS485 (18-22 AWG) cable between TAP and CCA.

Legacy configuration (same as Gateway):

- 120 TS4 units per TAP
- 360 TS4 units per CCA
- 7 TAPs per CCA
- 50ft (15m) radius with line of sight between TAP & all TS4 units

MISCELLANEOUS

Este equipamento não tem direito à proteção contra interferência prejudicial e não pode causar interferência em sistemas devidamente autorizados.

INSTALLATION COMPLETE

For more details on designing and installing solutions powered by Tigo, please visit:

[Tigo Academy](#)
[Resource Center](#)

Or contact us at:

training@tigoenergy.com

For sales info:

sales@tigoenergy.com or 1.408.402.0802

For technical information:

support.tigoenergy.com

For product info:

Visit www.tigoenergy.com/products

For additional info and product selection assistance, use Tigo's online design tool at www.tigoenergy.com/design

